

DESCRIPTION

The 27L2 (dual) is low cost, rail-to-rail input and output voltage feedback amplifier. It has a wide input common mode voltage range and output voltage swing, and take the minimum operating supply voltage down to 2.1V. The maximum recommended supply voltage is 5.5V. All are specified over the extended -40°C to +125°C temperature range.

The 27L2 provides 150kHz bandwidth at a low current consumption of 5.5µA per amplifier. Very low input bias currents enable the 27L2 to be used for integrators, photodiode amplifiers, and piezoelectric sensors. Rail-to-rail input and output are useful to designers for buffering ASIC in single-supply systems.

Application for this amplifier includes safety monitoring, portable equipment, battery and power supply control, and signal conditioning and interfacing for transducers in very low power systems.

The 27L2 dual comes in Green SOP8 package.

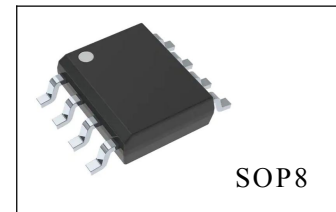

FEATURES

- Low Cost
- Rail-to-Rail Input and Output:
1mV Typical VOS
- Unity Gain Stable
- Gain-Bandwidth Product: 150kHz
- Supply Voltage Range: 2.1V to 5.5V
- Input Voltage Range:
-0.1V to +5.6V with $V_s = 5.5V$
- Low Supply Current: 5.5µA/Amplifier
- Small Packaging

APPLICATIONS

- ASIC Input or Output Amplifier
- Sensor Interface
- Piezoelectric Transducer Amplifier
- Medical Instrumentation
- Mobile Communication
- Audio Output Portable Systems
- Smoke Detectors
- Mobile Telephone
- Notebook PC
- PCMCIA Cards
- Battery-Powered Equipment

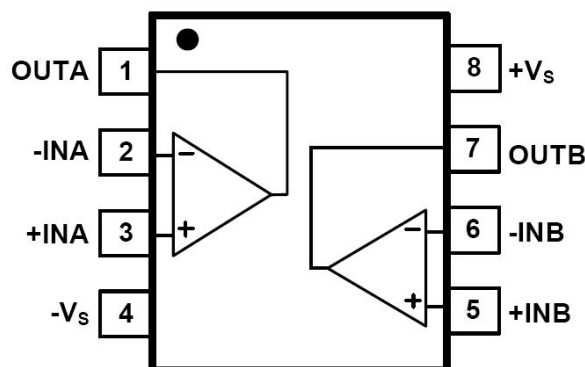
PIN CONFIGURATION

ABSOLUTE MAXIMUM RATINGS

Characteristic		Limit	Unit
Supply voltage		6	V
Common mode input voltage		$(-V_s)-0.3 \sim (+V_s)+0.3$	V
Storage temperature range		$-65 \sim +150$	°C
Junction temperature range		150	°C
Operating temperature range		$-40 \sim +125$	°C
Package thermal resistance@Ta=25°C		125	°C/W
Lead temperature (Soldering 10sec)		260	°C
ESD susceptibility	HBM	4000	V
	MM	400	

*Stresses beyond those listed under “Absolute Maximum Ratings” may cause permanent damage to the device. These are stress ratings only, and functional operation of the device at these or any other conditions beyond those indicated in the operational sections of the specifications is not implied. Exposure to absolute maximum rating conditions for extended periods may affect device reliability.

ELECTRICAL CHARACTERISTICS

($T_A=25^\circ\text{C}$, $V_S=+5\text{V}$, $R_L=500\text{k}\Omega$ connected to $V_S/2$ and $V_{OUT}=V_S/2$, unless otherwise specified.)

Characteristic	Symbol	Conditions	Min.	Typ.	Max	Unit
Input offset voltage	V_{OS}			1	3.5	mV
Quiescent current/amplifier	I_Q			5.5		μA
Open-Loop voltage gain	G_V	$V_O=0.015\text{V}$ to 4.985V , $R_L=500\text{k}\Omega$	90	110		dB
		$V_O=0.1\text{V}$ to 4.9V , $R_L=100\text{k}\Omega$	88	108		
Common mode rejection ratio	CMRR	$V_S=5.5\text{V}$, $-0.1\text{V} < V_{CM} < 5.6\text{V}$	60	87		dB
		$V_S=5.5\text{V}$, $-0.1\text{V} < V_{CM} < 4\text{V}$	70	114		
Power supply rejection ratio	PSRR	$V_S=2.5\text{V}$, $-0.1\text{V} < V_{CM} < 5.6\text{V}$	65	94		dB
Output current	I_{SOURCE}	$R_L=10\Omega$ to $V_S/2$	61	87		mA
	I_{SINK}		60	76		
Output voltage swing	V_{OH}		4.990	4.997		V
	V_{OL}			0.005	0.01	
Gain-Bandwidth product	GBP			150		kHz
Slew rate	SR	$R_L=100\text{k}\Omega$		0.05		$\text{V}/\mu\text{s}$
Voltage noise density	e_n	$f=1\text{kHz}$		85		$\text{nV}/\sqrt{\text{Hz}}$
		$f=10\text{kHz}$		44		

APPLICATION SUMMARY

Driving Capacitive Loads

The 27L2 can directly drive 250pF in unity-gain without oscillation. The unity-gain follower (buffer) is the most sensitive configuration to capacitive loading. Direct capacitive loading reduces the phase margin of amplifiers and this results in ringing or even

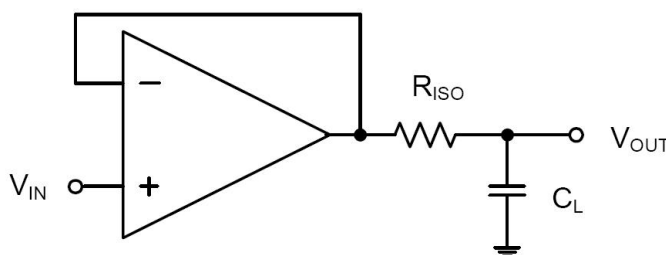

Fig1. Indirectly Driving Heavy Capacitive Load

oscillation. Applications that require greater capacitive driving capability should use an isolation resistor between the output and the capacitive load like the circuit in Fig1. The isolation resistor R_{ISO} and the load capacitor C_L form a zero to increase stability. The bigger the R_{ISO} resistor value, the more stable V_{OUT} will be. Note that this method results in a loss of gain accuracy because R_{ISO} forms a voltage divider with the R_{LOAD} .

An improved circuit is shown in Fig2. It provides DC accuracy as well as AC stability. R_F provides the DC accuracy by connecting the inverting signal with the output. C_F and R_{ISO} serve to counteract the loss of phase margin by feeding the high frequency component of the output signal back to the amplifier's inverting input, thereby preserving phase margin in the overall feedback loop.

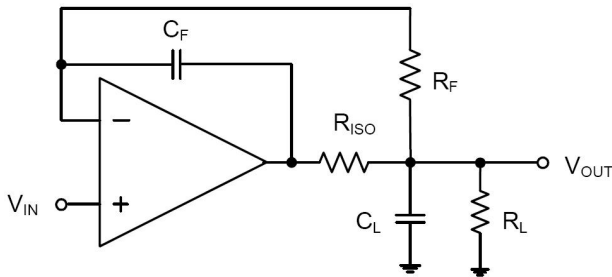

Fig2. Indirectly Driving Heavy Capacitive Load with DC Accuracy

For non-buffer configuration, there are two other ways to increase the phase margin: (a) by increasing the amplifier's gain or (b) by placing a capacitor in parallel with the feedback resistor to counteract the parasitic capacitance associated with inverting node.

Power-Supply Bypassing and Layout

The 27L2 operates from either a single +2.1V to +5.5V supply or dual $\pm 1.05V$ to $\pm 2.75V$ supplies. For single-supply operation, bypass the power supply $+V_S$ with a $0.1\mu F$ ceramic capacitor which should be placed close to the $+V_S$ pin. For dual-supply operation, both the $+V_S$ and the $-V_S$ supplies should be bypassed to ground with separate $0.1\mu F$ ceramic capacitors. $2.2\mu F$ tantalum capacitor can be added for better performance.

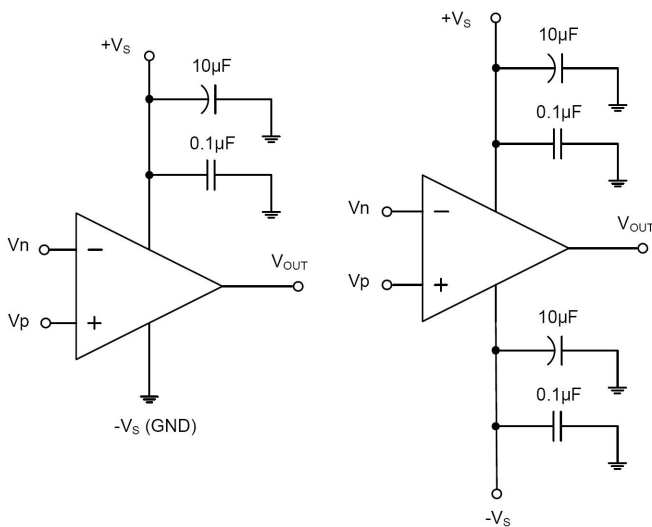

Fig3. Amplifier with Bypass Capacitors

Differential Amplifier

The circuit shown in Fig4 performs the difference function. If the resistor ratios are equal to ($R4/R3 = R2/R1$), then

$$V_{OUT} = (V_p - V_n) \times R2/R1 + V_{REF}.$$

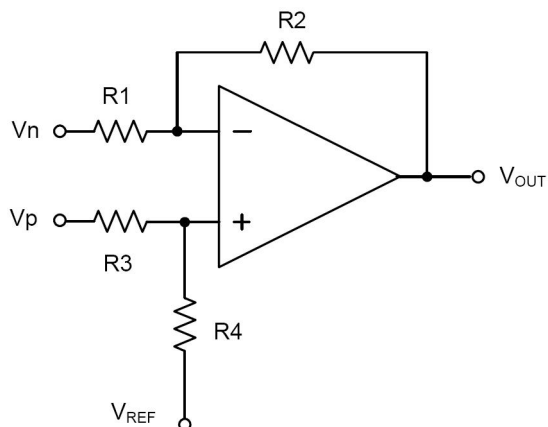

Fig4. Differential Amplifier

Instrumentation Amplifier

The circuit in Fig5 performs the same function as that in Fig4 but with a high input impedance.

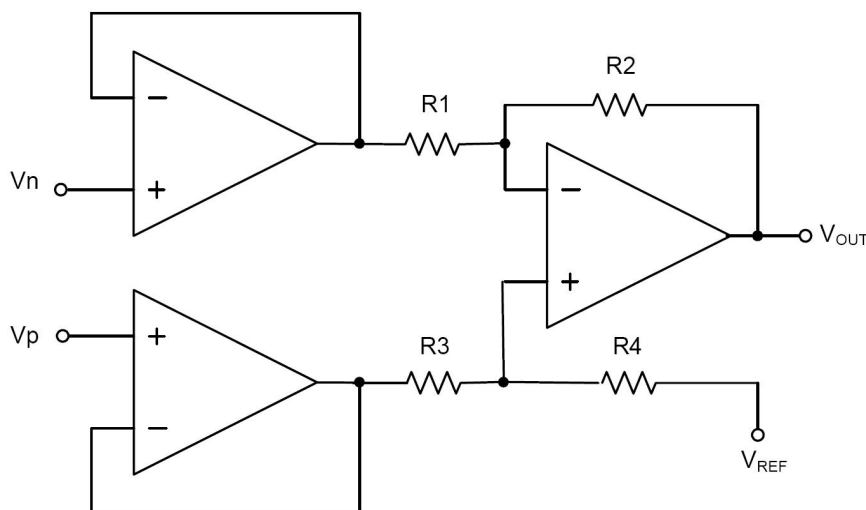

Fig5. Instrumentation Amplifier

Low Pass Active Filter

The low pass filter shown in Fig6 has a DC gain of $(-R2/R1)$ and the -3dB corner frequency is $1/2 \pi R2C$. Make sure the filter bandwidth is within the bandwidth of the amplifier. The large values of feedback resistors can couple with parasitic capacitance and cause undesired

effects such as ringing or oscillation in high-speed amplifiers. Keep resistor values as low as possible and consistent with output loading consideration.

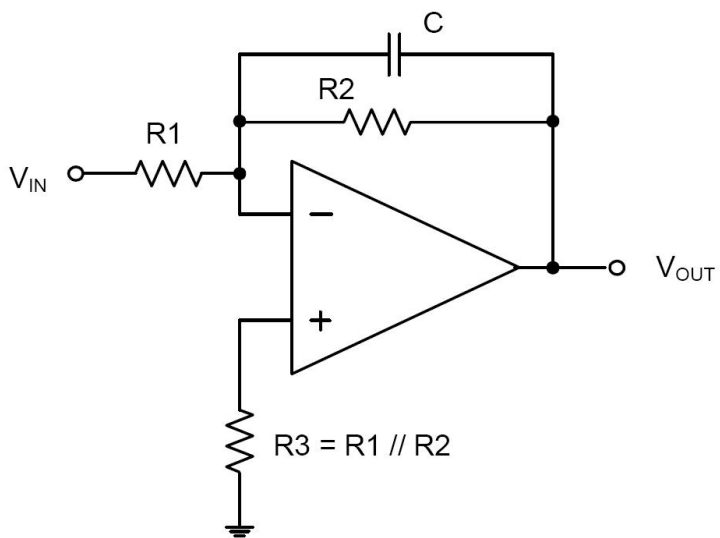
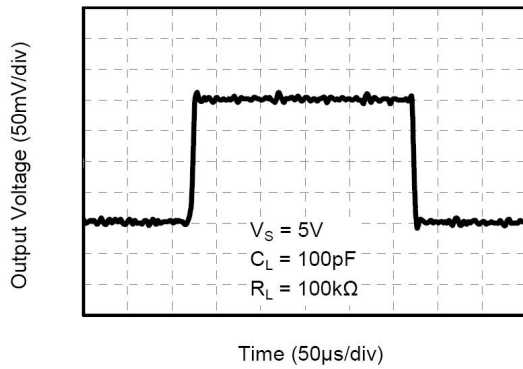

Fig6. Low Pass Active Filter

CHARACTERISTICS CURVES

At $T_A = +25^\circ\text{C}$, $V_S = +5\text{V}$ and $R_L = 500\text{k}\Omega$ connected to $V_S/2$, unless otherwise noted.

Small Signal Step Response



Large Signal Step Response

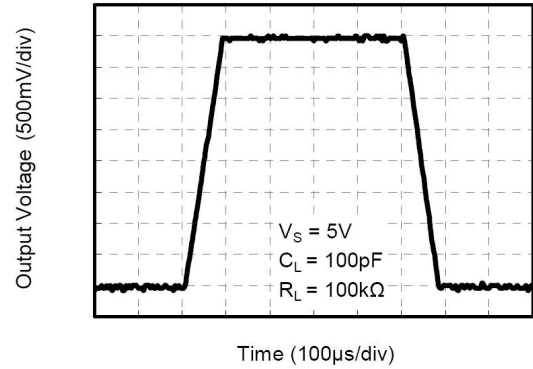

CMRR and PSRR vs. Frequency

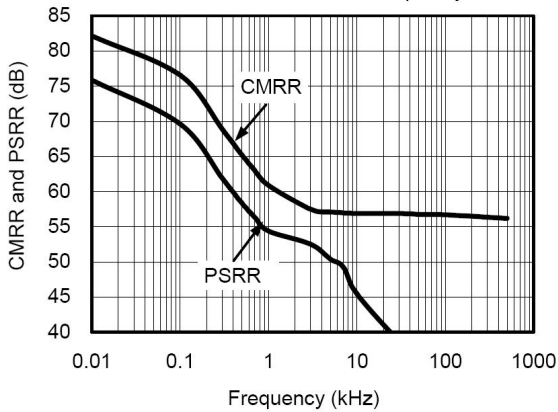

Maximum Output Voltage vs. Frequency

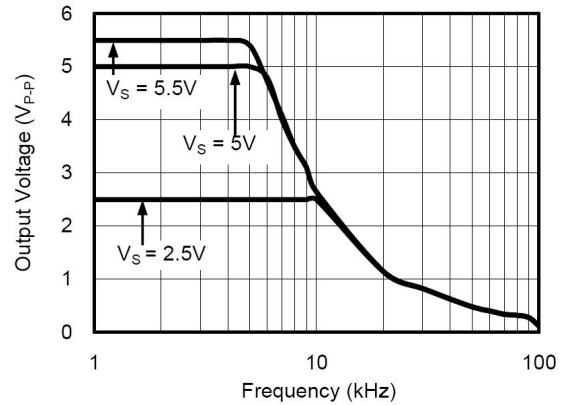

Small-Signal Overshoot vs. Load Capacitance

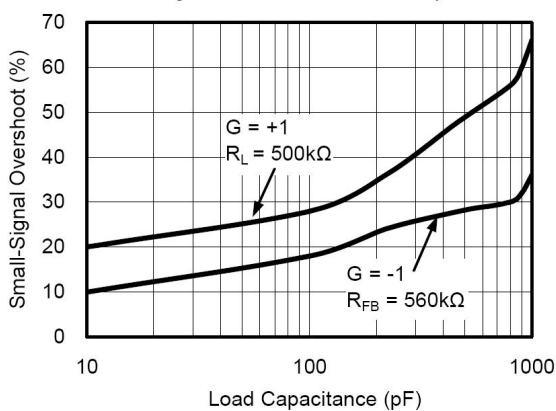

Input Voltage Noise Spectral Density vs. Frequency

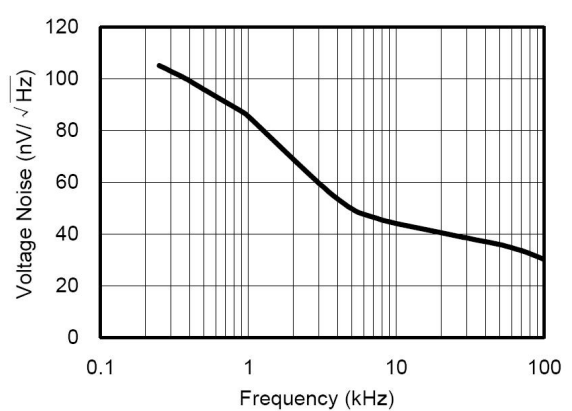

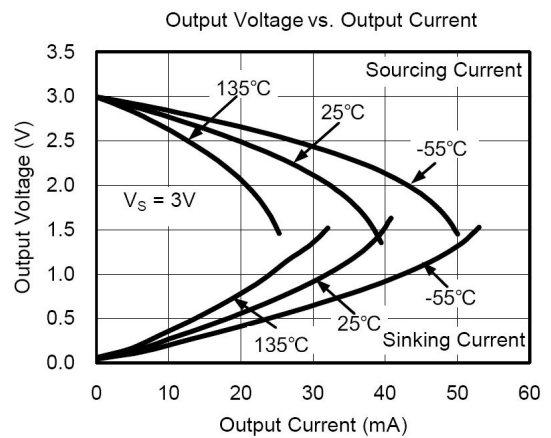
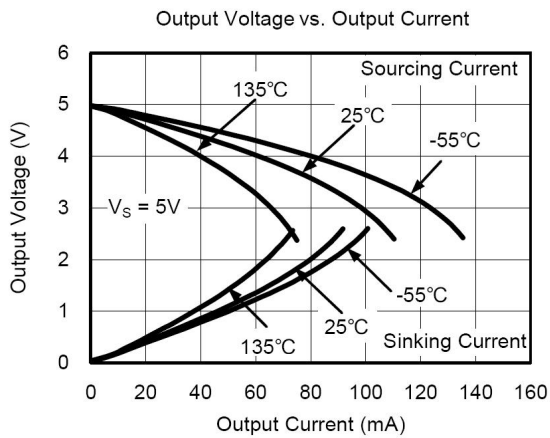
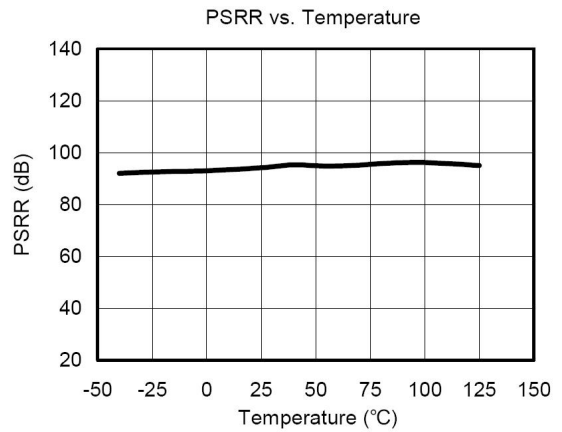
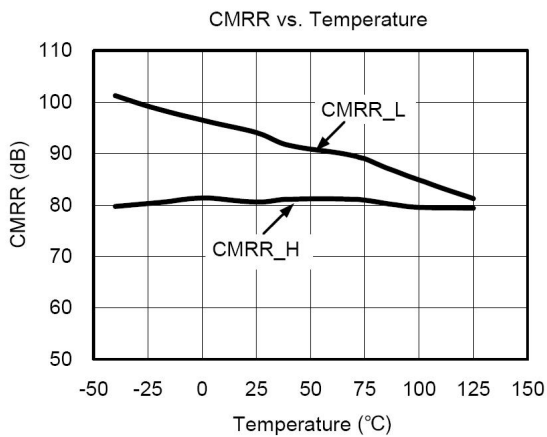
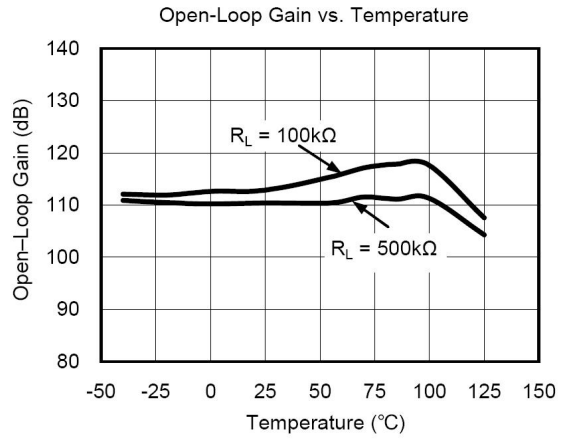
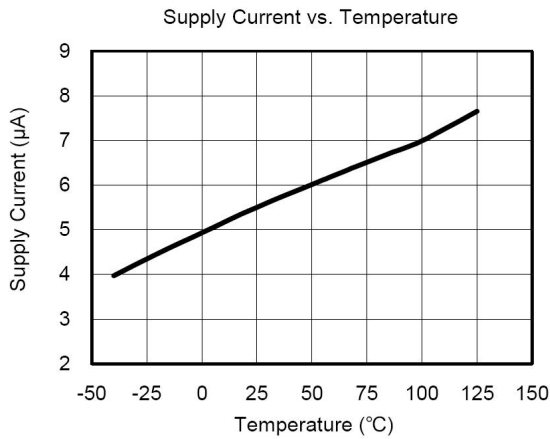

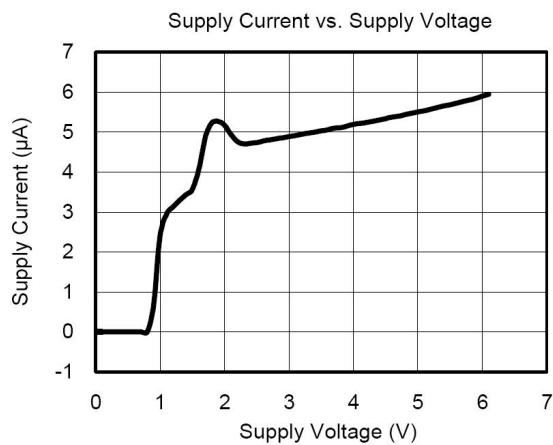
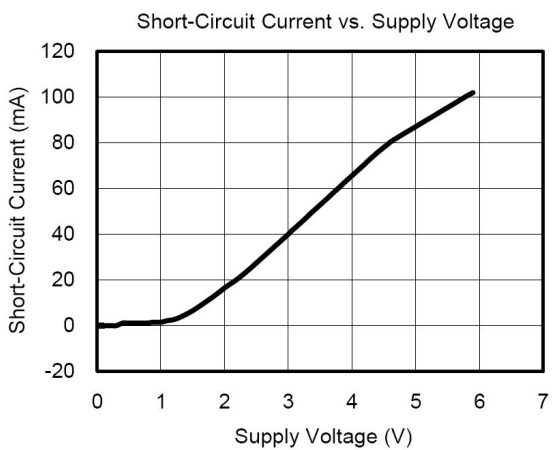

OUTLINE DRAWING
SOP8

Unit: mm

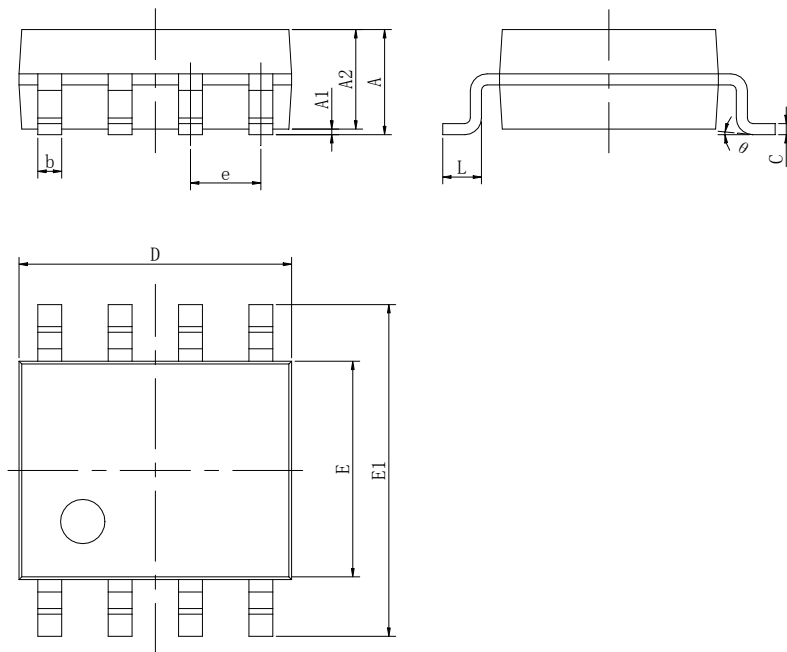

Symbol	Dimensions In Millimeters		Dimensions In Inches	
	Min	Max	Min	Max
A	1.350	1.750	0.053	0.069
A1	0.100	0.250	0.004	0.010
A2	1.350	1.550	0.053	0.061
b	0.330	0.510	0.013	0.020
c	0.170	0.250	0.006	0.010
D	4.700	5.100	0.185	0.200
E	3.800	4.000	0.150	0.157
E1	5.800	6.200	0.228	0.244
e	1.270(BSC)		0.050(BSC)	
L	0.400	1.270	0.016	0.050
θ	0°	8°	0°	8°