

Features

- 500-mA-Rated Collector Current(single output)
- High-Voltage Outputs:50V
- Output Clamp Diodes
- Inputs Compatible With Various Types of Logic
- Relay-Driver Applications

General Description

The ULN2003-G047 is high-voltage high-current Darlington transistor arrays each containing seven open collector common emitter pairs. Each pair is rated at 500mA. Suppression diodes are included for inductive load driving, the inputs and outputs are pinned in opposition to simplify board layout.

These devices are capable of driving a wide range of loads including solenoids, relays, DC motors, LED displays, filament lamps, thermal print-heads and high-power buffers.

The ULN2003-G047 is available in both a small outline 16-pin package (DIP16, SOP16 and_SSOP16).

Pin Assignments

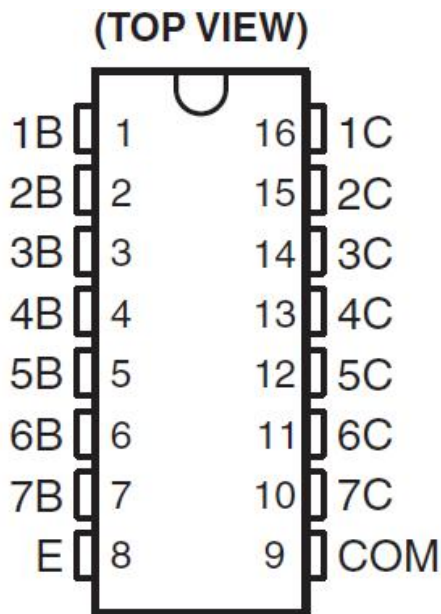

Connection Diagram

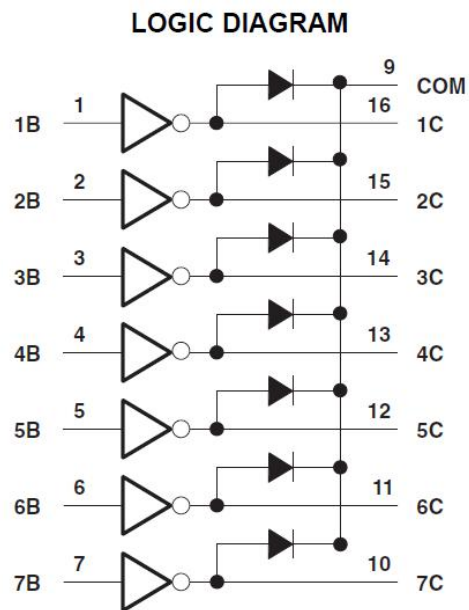

Pin Descriptions

| Pin Number | Pin Name | Function |
|------------|----------|-------------------------|
| 1 | 1B | Input pair1 |
| 2 | 2B | Input pair1 |
| 3 | 3B | Input pair1 |
| 4 | 4B | Input pair1 |
| 5 | 5B | Input pair1 |
| 6 | 6B | Input pair1 |
| 7 | 7B | Input pair1 |
| 8 | E | Common Emitter (ground) |
| 9 | COM | Common Clamp Diodes |
| 10 | 7C | Output pair7 |
| 11 | 6C | Output pair6 |
| 12 | 5C | Output pair5 |
| 13 | 4C | Output pair4 |
| 14 | 3C | Output pair3 |
| 15 | 2C | Output pair2 |
| 16 | 1C | Output pair1 |

Functional Block Diagram

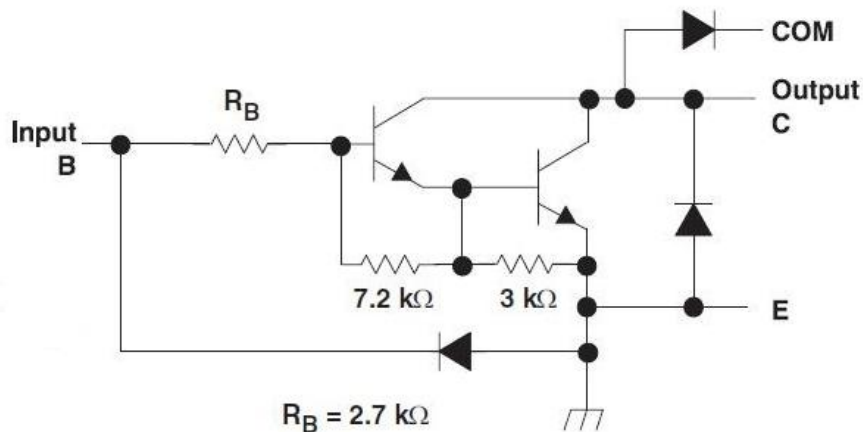

Note: All resistor values shown are nominal.

The collector-emitter diode is a parasitic structure and should not be used to conduct current. If the collector(s) go below ground an external Schottky diode should be added to clamp negative undershoots.



Absolute Maximum Ratings ⁽¹⁾

At 25°C free-air temperature (unless otherwise noted)

| Symbol | Parameter | | Min | Max | Unit |
|------------------|---|-----------------------------|-----|------|------|
| V _{CC} | Collector to emitter voltage | | | 50 | V |
| V _R | Clamp diode reverse voltage(2) | | | 50 | V |
| V _I | Input voltage(2) | | | 30 | V |
| I _{CP} | Peak collector current | See typical characteristics | | 500 | mA |
| I _{OK} | Output clamp current | | | 500 | mA |
| I _{TE} | Total emitter-terminal current | | | -2.5 | A |
| T _A | Operating free-air temperature range | ULN2003 | -20 | 70 | °C |
| θ _{JA} | Thermal Resistance Junction-to-Ambient(3) | | | 63 | °C/W |
| θ _{JC} | Thermal Resistance Junction-to-Case(4) | | | 12 | |
| T _J | Operating virtual junction temperature | | | 150 | °C |
| T _{STG} | Storage temperature range | | -65 | 150 | °C |
| ESD | Human Body Mode | | -- | 3000 | V |

- (1) Stresses beyond those listed under "absolute maximum ratings" may cause permanent damage to the device. These are stress ratings only, and functional operation of the device at these or any other conditions beyond those indicated under "recommended operating conditions" is not implied. Exposure to absolute-maximum-rated conditions for extended periods may affect device reliability.
- (2) All voltage values are with respect to the emitter/substrate terminal E, unless otherwise noted.
- (3) Maximum power dissipation is a function of T_{J(max)}, θ_{JA}, and T_A. The maximum allowable power dissipation at any allowable ambient temperature is $PD = (T_J(max) - T_A)/\theta_{JA}$. Operating at the absolute maximum T_J of 150°C can affect reliability.
- (4) Maximum power dissipation is a function of T_{J(max)}, θ_{JC}, and T_A. The maximum allowable power dissipation at any allowable ambient temperature is $PD = (T_J(max) - T_A)/\theta_{JC}$. Operating at the absolute maximum T_J of 150°C can affect reliability.

Recommended Operating Conditions

| Symbol | Parameter | Min | Max | Unit |
|-----------------|-------------------------------|-----|------|------|
| V _{CC} | Collector to Emitter voltage | - | 50 | V |
| T _A | Operating Ambient Temperature | -40 | +105 | °C |

Electrical Characteristics (TA=+25°C, unless otherwise specified)

| Parameter | | Test Figure | Test Conditions | | ULN2003-G047 | | | Unit |
|----------------------|--------------------------------------|-------------|---|-------------------------|--------------|------|-----|------|
| | | | | | MIN | TYP | MAX | |
| V _{I(on)} | On-state input voltage | Figure 6 | V _{CE} = 2 V | I _C = 200 mA | -- | -- | 2.4 | V |
| | | | | I _C = 250 mA | -- | -- | 2.7 | |
| | | | | I _C = 300 mA | -- | -- | 3 | |
| V _{CE(sat)} | Collector-emitter saturation voltage | Figure 5 | I _I = 250 μA, I _C = 100 mA | -- | 0.9 | 1.1 | V | |
| | | | I _I = 350 μA, I _C = 200 mA | -- | 1 | 1.3 | | |
| | | | I _I = 500 μA, I _C = 350 mA | -- | 1.2 | 1.6 | | |
| I _{CEX} | Collector cutoff current | Figure 1 | V _{CE} = 50 V, I _I = 0 | -- | -- | 50 | μA | |
| | | Figure 2 | V _{CE} = 50 V, T _A = +105°C, I _I = 0 | -- | -- | 100 | | |
| V _F | Clamp forward voltage | Figure 8 | I _F = 350 mA | -- | 1.7 | 2 | V | |
| I _{I(off)} | Off-state input current | Figure 3 | V _{CE} = 50 V, I _C = 500 μA | 50 | 65 | -- | μA | |
| I _I | Input current | Figure 4 | V _I = 3.85 V | -- | 0.93 | 1.35 | mA | |
| | | | V _I = 5 V | -- | -- | -- | | |
| | | | V _I = 12 V | -- | -- | -- | | |
| I _R | Clamp reverse current | Figure 7 | V _R = 50 V | | -- | -- | 50 | μA |
| | | | | T _A = 70°C | -- | -- | 100 | |
| C _i | Input capacitance | | V _I = 0, f = 1 MHz | -- | 15 | 25 | pF | |

Switching Characteristics (TA = +25°C, unless otherwise specified)

| Parameter | | Test Conditions | ULN2003-G047 | | | UNIT |
|------------------|---|--|--------------------|------|-----|------|
| | | | MIN | TYP | MAX | |
| t _{PLH} | Propagation delay time, low- to high-level output | See Figure 9 | | 0.25 | 1 | μs |
| t _{PHL} | Propagation delay time, high- to low-level output | See Figure 9 | | 0.25 | 1 | μs |
| V _{OH} | High-level output voltage after switching | V _S = 50 V, I _O = 300 mA, See Figure 9 | V _S -20 | | | mV |

Parameter Measurement Information

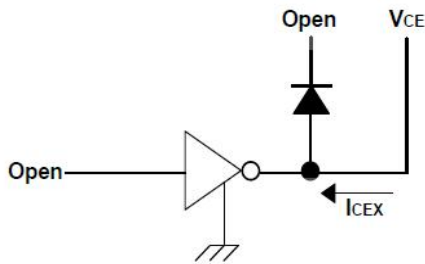

Fig.1 I_{CEX} Test Circuit

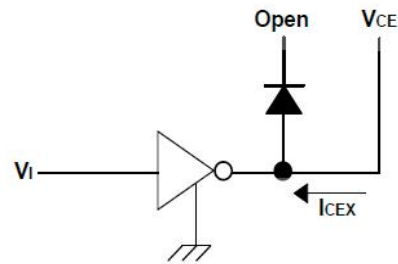

Fig.2 I_{CEX} Test Circuit

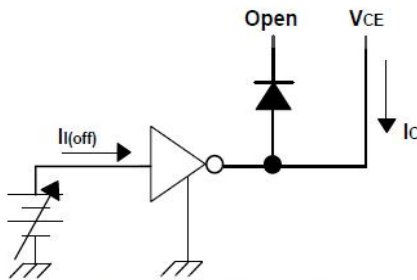

Fig.3 $I_{I(off)}$ Test Circuit

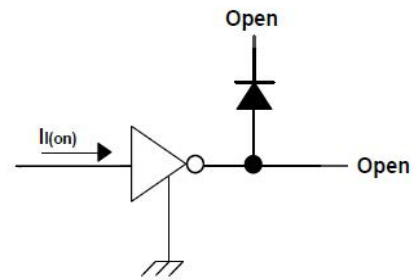

Fig.4 I_I Test Circuit

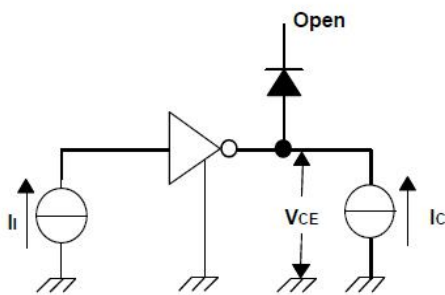

Fig. 5 h_{FE} , $V_{CE(sat)}$ Test Circuit

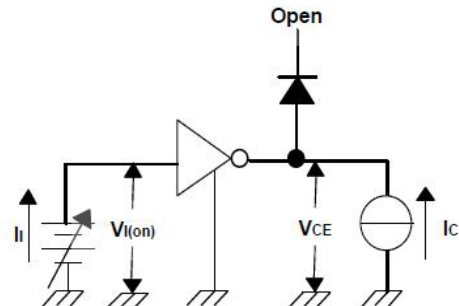

Fig. 6 $V_{I(on)}$ Test Circuit

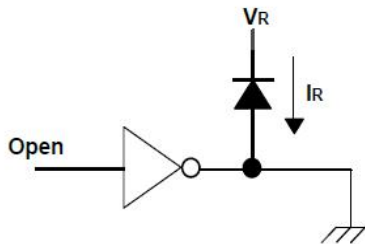

Fig. 7 I_R Test Circuit

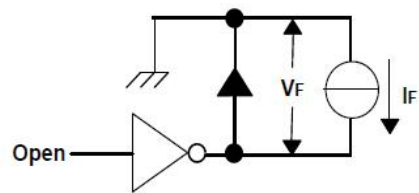

Fig. 8 V_F Test Circuit

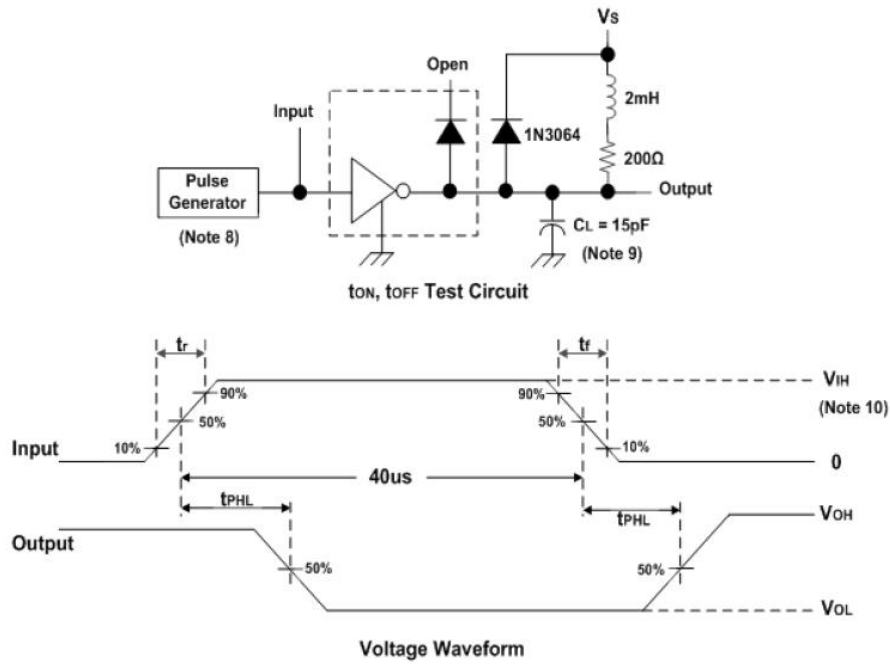

Fig. 9 Latch-Up Test Circuit and Voltage Waveform

Notes: 8. The pulse generator has the following characteristics:

Pulse Width=12.5Hz, output impedance 50Ω, $t_r \leq 5\text{ns}$, $t_f \leq 10\text{ns}$.

9. C_L includes probe and jig capacitance.

10. $V_{IH} = 3\text{V}$

DIP16 Outline Dimensions

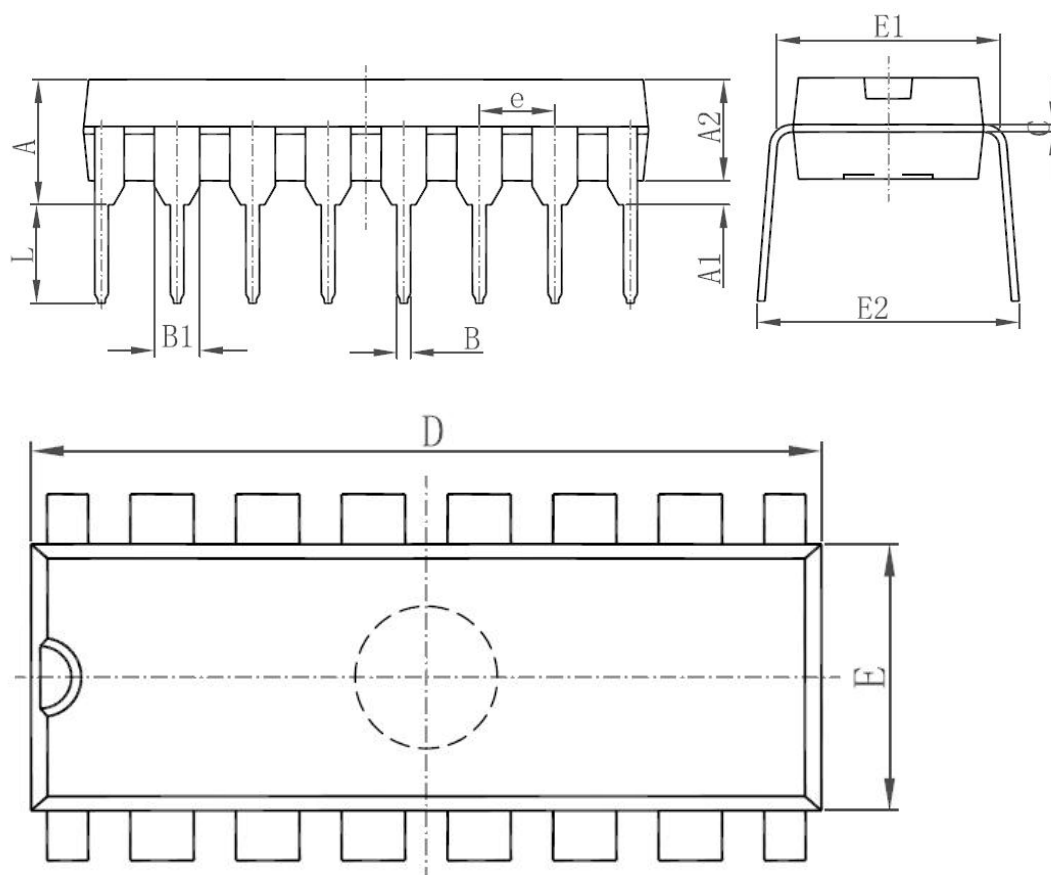

| Symbol | Dimensions In Millimeters | | Dimensions In Inches | |
|--------|---------------------------|--------|----------------------|-------|
| | Min | Max | Min | Max |
| A | 3.710 | 4.310 | 0.146 | 0.170 |
| A1 | 0.510 | | 0.020 | |
| A2 | 3.200 | 3.600 | 0.126 | 0.142 |
| B | 0.380 | 0.570 | 0.015 | 0.022 |
| B1 | 1.524 (BSC) | | 0.060 (BSC) | |
| C | 0.204 | 0.360 | 0.008 | 0.014 |
| D | 18.800 | 19.200 | 0.740 | 0.756 |
| E | 6.200 | 6.600 | 0.244 | 0.260 |
| E1 | 7.320 | 7.920 | 0.288 | 0.312 |
| e | 2.540 (BSC) | | 0.100 (BSC) | |
| L | 3.000 | 3.600 | 0.118 | 0.142 |
| E2 | 8.400 | 9.000 | 0.331 | 0.354 |

SOP16 Outline Dimensions

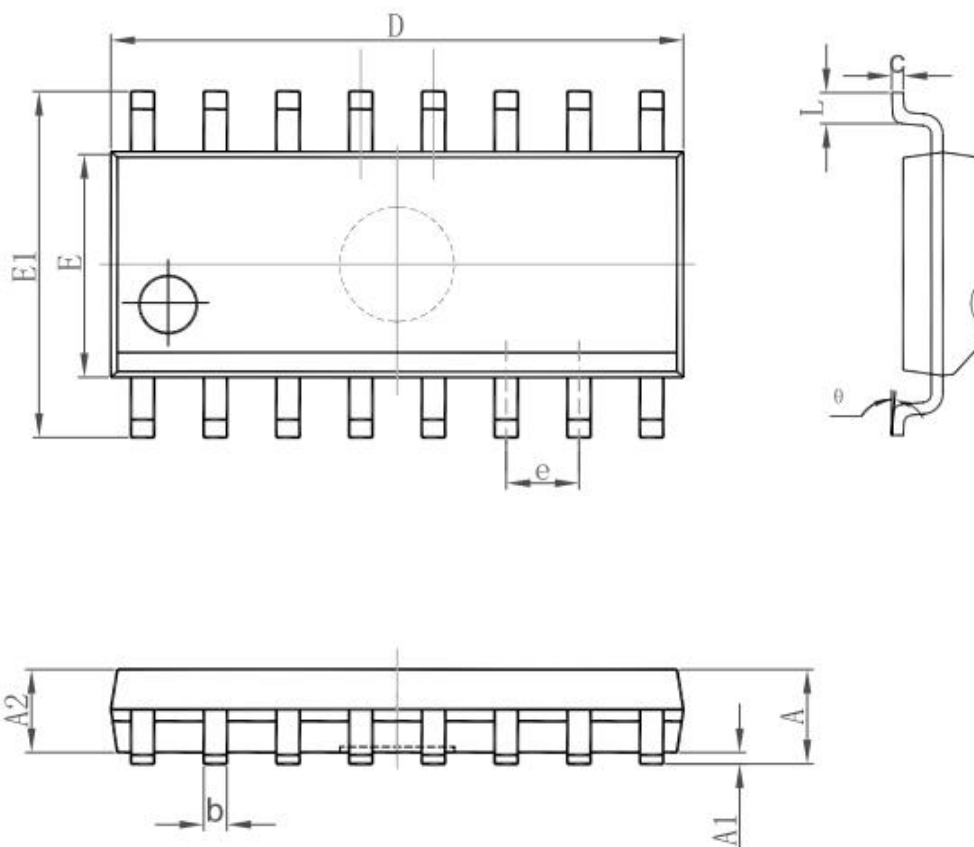

| Symbol | Dimensions In Millimeters | | Dimensions In Inches | |
|--------|---------------------------|--------|----------------------|-------|
| | Min | Max | Min | Max |
| A | 1.350 | 1.750 | 0.053 | 0.069 |
| A1 | 0.100 | 0.250 | 0.004 | 0.010 |
| A2 | 1.350 | 1.550 | 0.053 | 0.061 |
| b | 0.330 | 0.510 | 0.013 | 0.020 |
| c | 0.170 | 0.250 | 0.007 | 0.010 |
| D | 9.800 | 10.200 | 0.386 | 0.402 |
| E | 3.800 | 4.000 | 0.150 | 0.157 |
| E1 | 5.800 | 6.200 | 0.228 | 0.244 |
| e | 1.270 (BSC) | | 0.050 (BSC) | |
| L | 0.400 | 1.270 | 0.016 | 0.050 |
| θ | 0° | 8° | 0° | 8° |

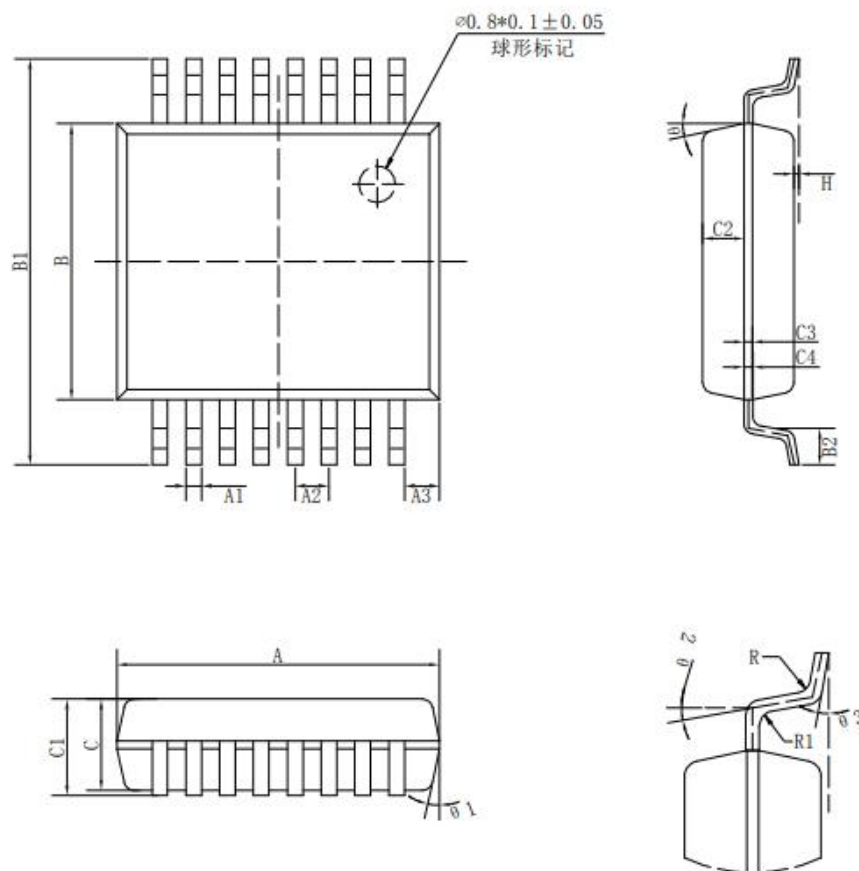
SSOP16 Outline Dimensions

| 标注 | 尺寸 | 最小(mm) | 最大(mm) | 标注 | 尺寸 | 最小(mm) | 最大(mm) |
|----|----|----------|--------|------------|----|----------|--------|
| A | | 6.15 | 6.25 | C3 | | 0.152 | |
| A1 | | 0.30TYP | | C4 | | 0.172 | |
| A2 | | 0.65TYP | | H | | 0.05 | 0.15 |
| A3 | | 0.675TYP | | θ | | 12° TYP4 | |
| B | | 5.25 | 5.35 | $\theta 1$ | | 12° TYP4 | |
| B1 | | 7.65 | 7.95 | $\theta 2$ | | 10° TYP | |
| B2 | | 0.60 | 0.80 | $\theta 3$ | | 0° ~ 8° | |
| C | | 1.70 | 1.80 | R | | 0.20TYP | |
| C1 | | 1.75 | 1.95 | R1 | | 0.15TYP | |
| C2 | | 0.799 | | | | | |